

V1H5023 V1H5025

Natural frequency : (1)
15 to 25 Hz

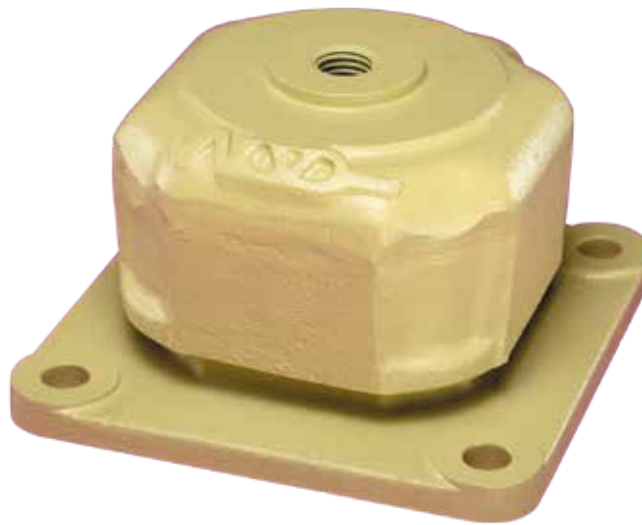

DESCRIPTION

The V1H5023 and V1H5025 mounts have cast iron upper housing and base. The base has four fixing holes.
The resilient elements are stainless steel wire mesh cushions. The cast iron parts are painted.

APPLICATIONS

Isolation of machine-tools : grinding machines, crushing machines, fly-presses, printing machines, textile machinery, etc.

Isolation of rotating machines : engines, sets, pumps, etc. rotating over 2500 rpm.

Marine : isolation of exhaust pipes, manifold, boilers, motors, sets, pumps, etc.

(1) Natural frequencies with max/min loads, see : OPERATING CHARACTERISTICS.

DIMENSIONS

FV1 = axial force in compression
 FV2 = axial force in traction
 FH = radial force

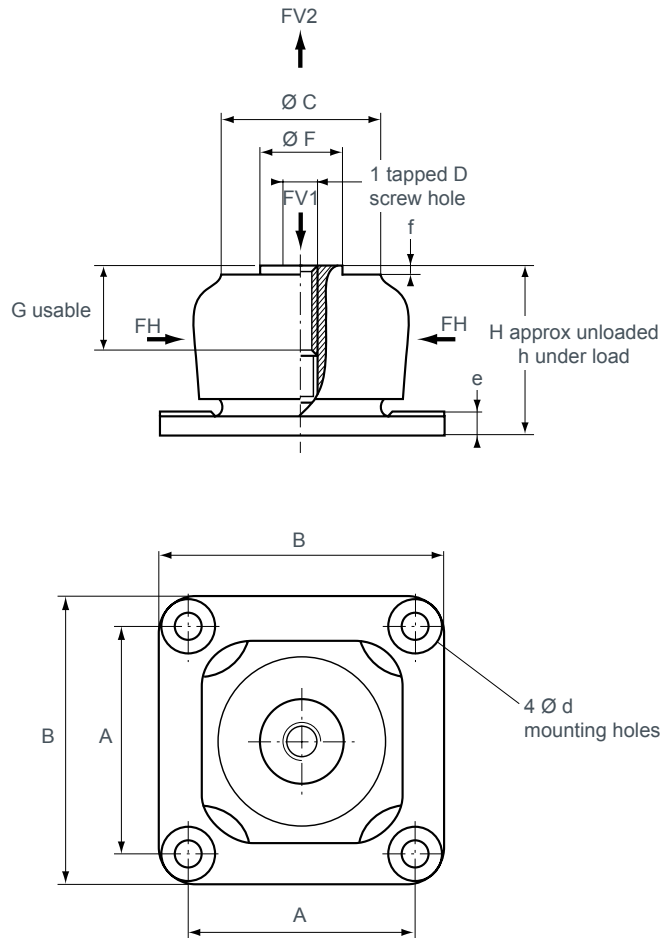

Reference	A (mm)	B (mm)	$\varnothing C$ (mm)	D	$\varnothing E$ (mm)	G (mm)	H (mm)	$\varnothing d$ (mm)	e (mm)	f (mm)	h under FV1 (mm)	h under FV2 (mm)
V1H5025*	138	172	100	M20	50	50	100	15	12	5	96	104
V1H5023*	215	260	140	M33	70	60	136	23	18	7	132	140

* Load indice, see below.

OPERATING CHARACTERISTICS

Maximum permitted excitation at natural frequency of suspension : ± 0.3 mm.

- Natural frequencies for this amplitude :
 - axial } 15 to 25 Hz depending on load.
 - radial }
- Amplification factor at resonance : < 4 .
- Structural strength : see table.
- Operating temperature : $- 70^{\circ}\text{C}$ to $+ 300^{\circ}\text{C}$.

Reference	Static axial load (daN)	Maximum dynamic forces (daN)			Weight (kg)
		Axial compression	Axial tension	Radial	
V1H5025-01 V1H5025-02	350 - 900 800 - 3 000	4 500 15 000	4 500 4 500	4 500 4 500	6,7
V1H5023-01 V1H5023-02	1 000 - 2 500 2 000 - 7 000	12 500 35 000	12 500 12 500	12 500 12 500	24,4